



Ford, Lincoln SUV/Trucks 1997-2004

See applications on page 2

Visit MetraOnline.com for more detailed information about the product and up-to-date vehicle specific applications

KIT FEATURES

- DDIN radio provisions. (sub-dash modifications are required)
- Custom textured replacement dash panel to accommodate DDIN radios. Metra suggests painting factory vents black to match the replacement dash panel.
- Multiple trim panels and brackets to cover multiple trim levels and vehicle options.

KIT COMPONENTS

- A) Dash panel • B) Manual climate panel • C) Manual climate brackets • D) Auto climate panel • E) Auto climate brackets • F) 3-position 4WD switch panel • G) 4-position 4WD switch panel • H) Drive position switch back covers • I) Airbag switch panel • J) Blank panels (2) • K) Panel clips (5) • L) #4 x 3/8" Phillips screws (4) • M) #8 x 3/8" Phillips screws (16)

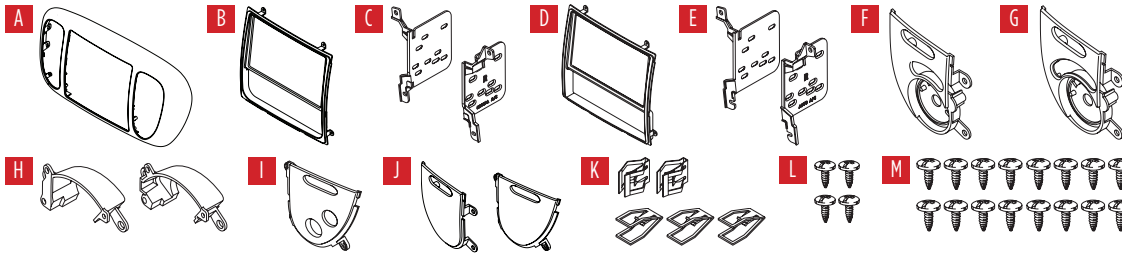

TABLE OF CONTENTS

Dash Disassembly	2-3
Kit Preparation.....	4-5
Kit Assembly	6

WIRING & ANTENNA CONNECTIONS (sold separately)

Wiring Harness: Please visit metraonline.com for wiring harness options.
Antenna Adapter: Not required

TOOLS REQUIRED

- Panel removal tool • Phillips screwdriver
- Socket wrench • Cutting tool

Attention! With the key out of the ignition, disconnect the negative battery terminal before installing this product. Ensure that all installation connections are secure before cycling the ignition to test this product.

APPLICATIONS

Ford

Expedition1997-2002

F-1501997-2003

F-150 Heritage.....2004

F-2501998

Lincoln

Blackwood2002

Navigator1997-2002

DASH DISASSEMBLY

1. Unsnap and remove the dash panel.
(Figure A)
2. Remove the factory radio using Metra's 86-5618 radio removal tools.
(Figure B)
3. Remove the climate controls (recommended for sub-dash cutting).
(Figure B)
4. Remove (2) 7/32" screws and unsnap the factory vents from the dash panel.
(Figure C)

Continued on the next page

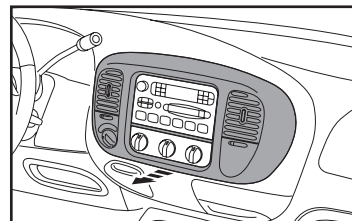

(Figure A)

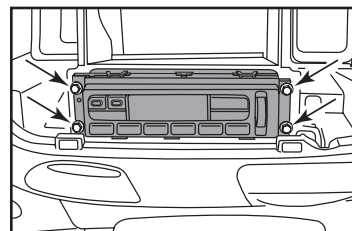

(Figure B)

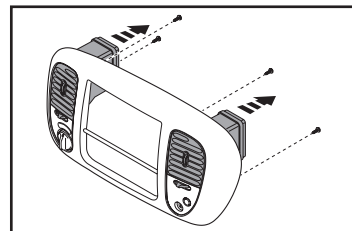

(Figure C)

DASH DISASSEMBLY (CONT.)

If equipped, there is a 3-position or a 4-position drive position switch. Remove switches from factory dash panel:

4. Remove 4wd knob from front. (Figure D)
5. (2) 5.5mm screws from the switch. (Figure D)
6. Grind down 3 tabs to remove the light pipe cover and drive position graphic with icons. **Note:** Be careful not to cut into the factory drive position graphic, it will be re-used along with the factory light pipe. (clear plastic) (Figure E)
7. Carefully remove the drive position graphic. (Figure E)
8. If equipped, remove the factory passenger airbag indicator and switch. (Figure F)

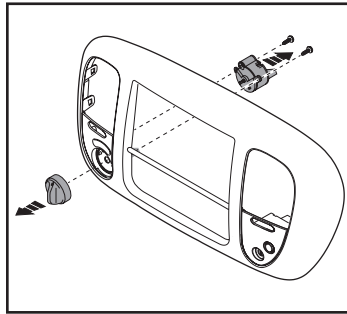

(Figure D)

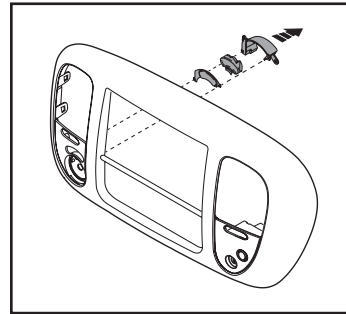

(Figure E)

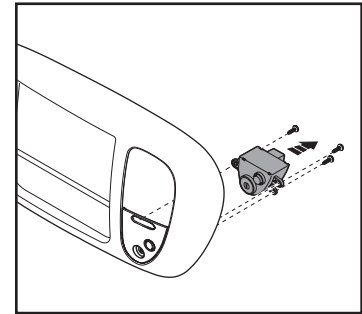

(Figure F)

Continue to Kit Preparation

KIT PREPARATION

If equipped with the factory drive position switch:

1. Snap the **drive position switch panel** into place and secure with (2) factory screws (extra hardware is provided if needed). (Figure A)
2. Place the graphic into the **drive position switch panel** (either 3 position or 4 position). (Figure B)
3. Place the factory light pipe (clear plastic) into position and then the back cover. (Figure C)
4. Secure the switch with the remaining factory screws (extra hardware is provided if needed) Install the knob from the front. (Figure D)

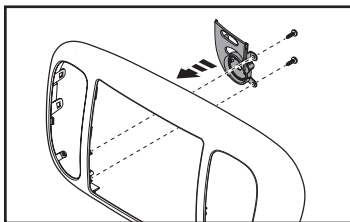

(Figure A)

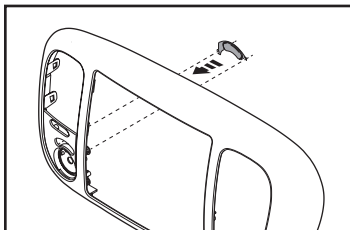

(Figure B)

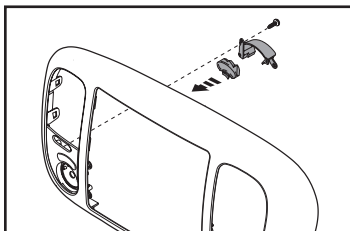

(Figure C)

If equipped with the factory passenger airbag switch:

1. Snap the airbag switch panel into place and secure with the factory hardware (extra hardware is provided if needed). (Figure E)
2. Secure the factory switch into place using the factory hardware. (extra hardware is provided if needed). (Figure F)

Continued on the next page

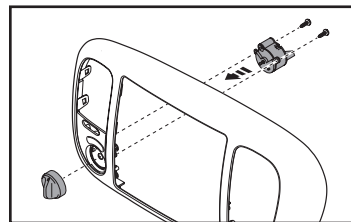

(Figure D)

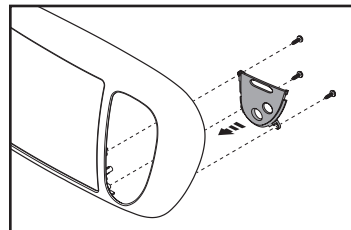

(Figure E)

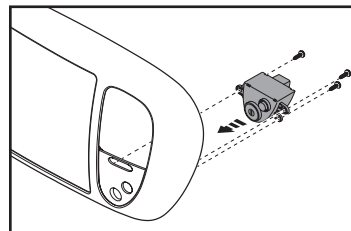

(Figure F)

KIT PREPARATION (CONT.)

Select either the manual climate or auto climate trim panel and brackets.

1. Secure the appropriate **climate panel** to the **dash panel** using the (4) supplied #4 x 3/8" screws. (Figure G)
2. Attach the (5) supplied **panel clips** to the radio housing. (factory panel clips can be used) (Figure H)
3. Metra recommends painting the vents matte black to better match the replacement dash panel.

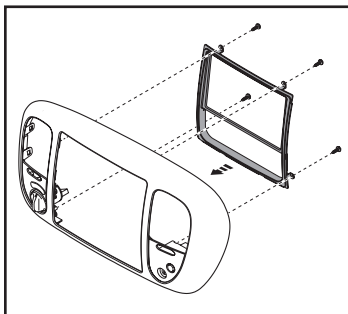

(Figure G)

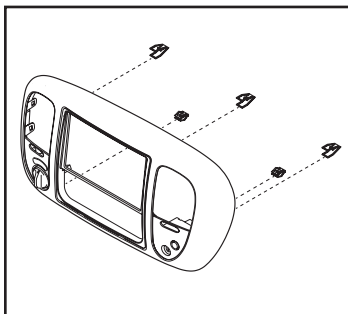

(Figure H)

4. Attach the vents to the **radio housing** using the factory hardware (Figure I)
5. Cut sub dash area. Top and sides. Remove rear support. Might need to trim the sub dash bracket (radio opening) (Figure J)
6. Install the climate controls back into the sub dash.

Continue to Kit Assembly

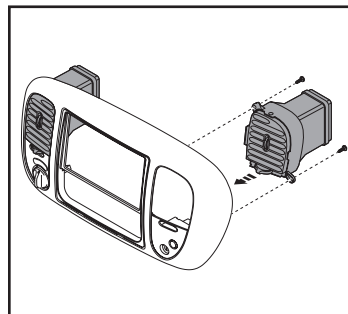

(Figure I)

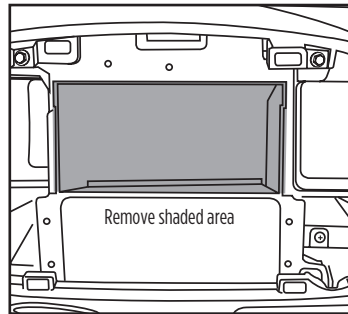

(Figure J)

KIT ASSEMBLY

1. Attach the appropriate **radio brackets** to the radio using screws supplied with the radio, and then secure into the dash opening. (Figure A)
2. Locate the factory wiring harness and antenna connector in the dash, and complete all necessary connections to the radio. Metra recommends using the proper mating adapter from Metra and/or AXXESS. Re-connect the negative battery terminal and test the radio for proper operation.
3. Snap the **radio trim panel** over the radio and reassemble the dash in reverse order of disassembly.

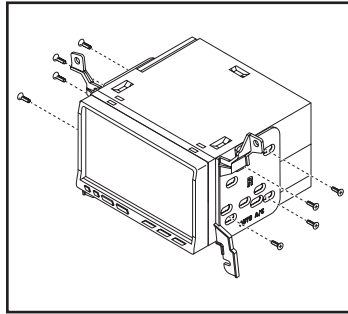

(Figure A)



DP-5859
INSTALLATION INSTRUCTIONS



Having difficulties? We're here to help.



Contact our Tech Support line at:

386-257-1187



Or via email at:

techsupport@metra-autosound.com

Tech Support Hours (Eastern Standard Time)

Monday - Friday: 9:00 AM - 7:00 PM

Saturday: 10:00 AM - 5:00 PM

Sunday: 10:00 AM - 4:00 PM



**Metra recommends MECP
certified technicians**