



Dodge/Jeep/Ram† Camera Interface With Pre-Wired Harness 2013-Up

† With 8.4-inch U-Connect radio

Visit AxxessInterfaces.com for more detailed information about the product and up-to-date vehicle specific applications

INTERFACE FEATURES

- (4) Camera inputs
- Reverse signal trigger generated via CAN bus communication of the vehicle
- Turn signal trigger generated via CAN bus communication of the vehicle
- (4) Programmable camera control wires
- Micro-B USB updatable

INTERFACE COMPONENTS

- AXAC-CH5 interface
- AXAC-CH5 interface harness
- AXAC-CH5 vehicle harness

APPLICATIONS

Dodge		Jeep		RAM			
Challenger	2015-Up	Grand Cherokee	2014-Up	1500 (DS chassis code)	2019	3500	2013-2018
Charger	2015-Up			1500	2013-2018		
Durango	2014-Up			2500	2013-2018		

TABLE OF CONTENTS

Introduction.....	2
Configuration	2-4
Connections.....	5
Installation	6
Programming.....	6

REQUIRED ITEMS (sold separately)

Update Cable: AXUSB-MCBL

TOOLS REQUIRED

- Crimping tool and connectors, or solder gun, solder, and heat shrink
- Tape • Wire cutter • Zip ties

CAUTION! All accessories, switches, climate controls panels, and especially air bag indicator lights must be connected before cycling the ignition. Also, do not remove the factory radio with the key in the on position, or while the vehicle is running.

INTRODUCTION

The AXAC-CH5 is a camera switching interface that provides up to (3) additional camera inputs to the factory radio, while still retaining the factory camera. With this interface a front camera, and/or side cameras, can be added to the factory radio. The cameras function automatically, no human interaction required, unless desired to do so. The interface can also be used if the vehicle doesn't come equipped with a backup camera, adding up to (4) cameras in this scenario. Axxess recommends cameras from the iBEAM product line for best results.

CONFIGURATION

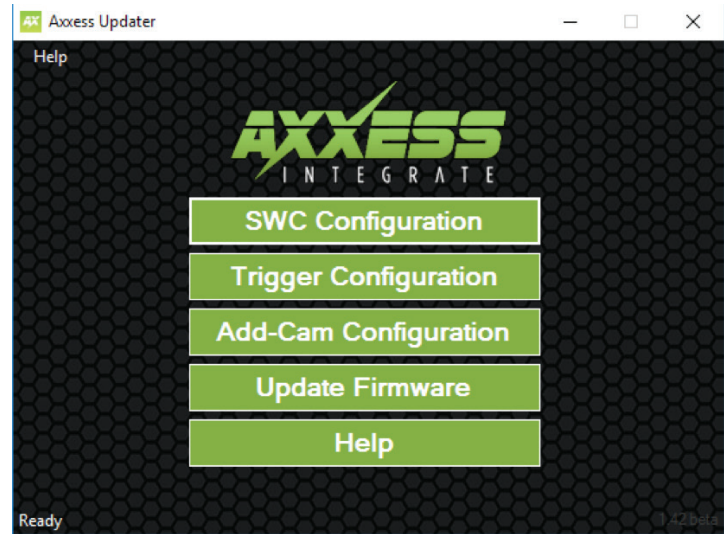

- Download and install the Axxess Updater available at: AxxessInterfaces.com
- Connect the AXUSB-MCBL update cable (sold separately) between the interface and the computer. The cable will connect into the micro-B USB port in the interface.
- Open the Axxess Updater and wait until the word **Ready** is listed in the bottom left of the screen.
- Select **Add-Cam Configuration**.

Continued on the next page

CONFIGURATION (CONT.)

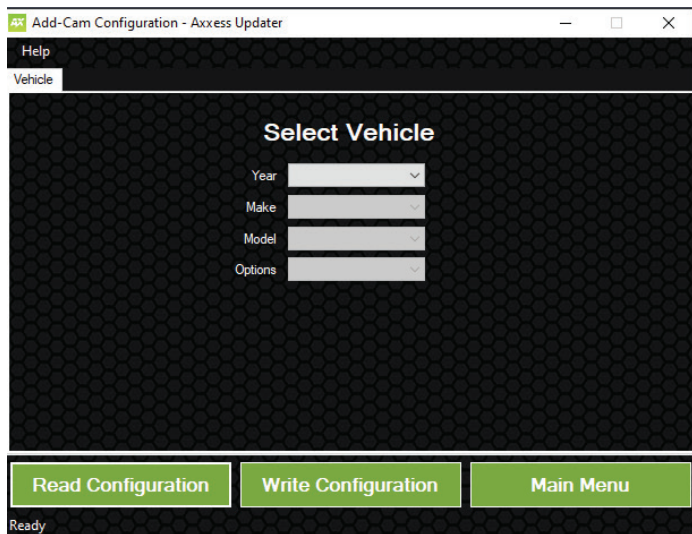

- Select the vehicle in the drop down list. A tab labeled **Configuration** will appear after the vehicle has been selected.

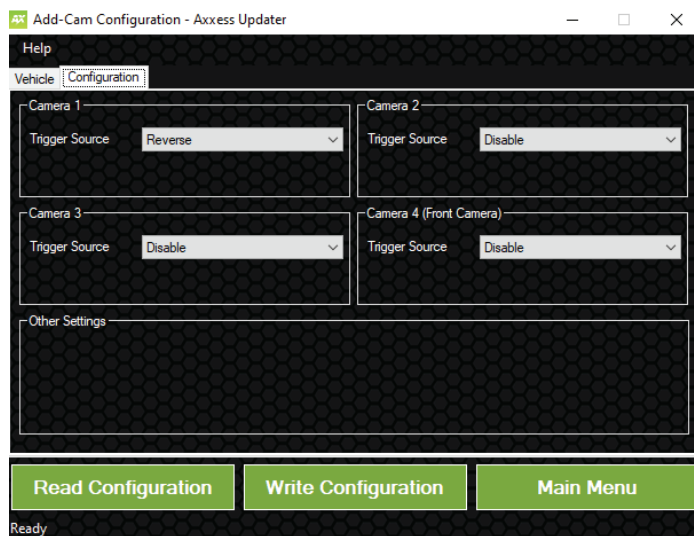

- Under **Configuration**, configure the (4) video trigger inputs to the desired settings. †
- Once all selections have been configured, press **Write Configuration** to save the settings.
- Unplug the update cable from the interface and computer.
 - † Refer to the following page for more information.

Continued on the next page

CONFIGURATION (CONT.)

Video trigger legend

- Disable (will turn off the input)
- Backup Camera (dedicated backup camera)
- Left Blinker (will be used for activation)
- Right Blinker (will be used for activation)
- Control 1 (positive trigger activation)
- Control 1 (negative trigger activation)
- Control 2 (positive trigger activation)
- Control 2 (negative trigger activation)
- Control 3 (positive trigger activation)
- Control 3 (negative trigger activation)
- Control 4 (positive trigger activation)
- Control 4 (negative trigger activation)
- Auto (Reverse -> Drive) will activate once that sequence is seen (only available for video trigger 4)

Video trigger description

- **Reverse camera:** Dedicated by default to Video Trigger 1. Will activate the backup camera while the vehicle is in reverse.
- **Left blinker:** Activation of the left turn signal will activate the left camera.
- **Right blinker:** Activation of the right turn signal will activate the right camera.
- **Auto (reverse -> drive):** Available only for Video Trigger 4, when installing a front camera. With this feature selected, the camera will activate automatically once a reverse-then-drive sequence is seen from the vehicle. Example of this scenario would be while parallel parking the vehicle. As an alternative, a control wire can be used instead to manually activate the camera.
Note: Auto (Reverse -> Drive) will disable the camera once 15 MPH is reached. A control wire activated will also disable the camera.
Note: If the control wire is activated while driving, the camera will activate and deactivate during stop-and-go traffic.
- **Control 1-4 (positive or negative) trigger activation wires:** Can be used as a positive or negative trigger to manually activate a camera via a toggle switch, or similar device.

CONNECTIONS

For models with a factory backup camera:

The camera signal will need to be interrupted and connected to the corresponding input/output RCA jacks from the interface.

- Connect the RCA jack from the **AXAC-CH5 vehicle harness** labeled “Camera input”, to the RCA jack from the **AXAC-CH5 interface harness** labeled “Camera output”.
- Connect the RCA jack from the **AXAC-CH5 vehicle harness** labeled “Camera output”, to the RCA jack from the **AXAC-CH5 interface harness** labeled “Camera 1”.
- Disregard the following (3) wires: **Blue/Green, Green/Blue, Red**

For models without a factory backup camera:

- Connect the RCA jack from the **AXAC-CH5 vehicle harness** labeled “Camera input”, to the RCA jack from the **AXAC-CH5 interface harness** labeled “Camera output”.
- Connect the RCA jack from the **AXAC-CH5 interface harness** labeled “Camera 1”, to the aftermarket backup camera.
- Disregard the RCA jack labeled “Camera output” from the **AXAC-CH5 vehicle harness**.
- Connect the **Red** wire from the **AXAC-CH5 interface harness** labeled “Camera 12V”, to the power wire from the aftermarket backup camera.
- Disregard the following (2) wires: **Blue/Green, Green/Blue**

Camera Input:

Camera 1	Backup camera input
Camera 2	Left or right camera, user assignable
Camera 3	Left or right camera, user assignable
Camera 4	Front camera

Analog control trigger wires:

The (optional) analog control wires can be used with either a negative or positive trigger, depending on how they are configured in the Axxess Updater. These wires will only be used for manual control of the camera(s). Otherwise disregard them.

Control Wire	Wire Color
Control 1	Gray/Blue
Control 2	Gray/Red
Control 3	Orange
Control 4	Orange/White

INSTALLATION

With the ignition cycled off:

1. Remove the harness from the factory radio, then install the **AXAC-CH5 vehicle harness** in between.
2. Connect the **AXAC-CH5 vehicle harness** to the **AXAC-CH5 interface harness**.
3. Connect the **AXAC-CH5 interface harness** to the **AXAC-CH5 interface**.
4. Make sure the camera(s) is connected to the appropriate input.
5. Make sure the interface has been configured beforehand as shown in the Configuration section. Failure to configure the interface will result in the interface not functioning properly.

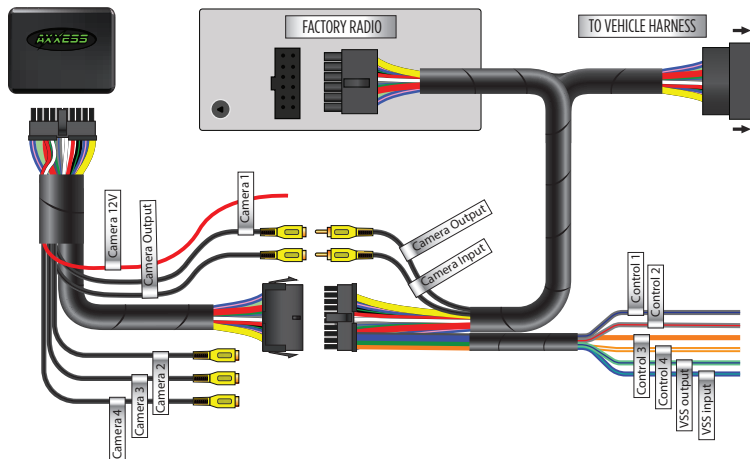

PROGRAMMING

For models with a factory backup camera:

1. Cycle the ignition on and wait until the LED in the interface comes on.
Note: If the LED doesn't come on within a few seconds, yet blinks instead, turn the key to the off position, disconnect the interface, check all connections, reconnect the interface, and then try again.
2. Test all functions of the installation for proper operation.

For models without a factory backup camera:

The factory radio requires two 5-minute key cycles to accept the interface.

1. With the ignition cycled off and all doors shut, wait for the dome light to go out.
2. Cycle the ignition on for 30-seconds.
3. Cycle the ignition off, wait for the dome light to go out, then wait 5-minutes.
4. Cycle the ignition on for 30-seconds.
5. Cycle the ignition off, wait for the dome light to go out, then wait 5-minutes.
6. Cycle the ignition on, then test all functions of the installation for proper operation.





AXAC-CH5

INSTALLATION INSTRUCTIONS



IMPORTANT

If you are having difficulties with the installation of this product, please call our Tech Support line at 386-257-1187. Before doing so, look over the instructions a second time, and make sure the installation was performed exactly as the instructions are stated. Please have the vehicle apart and ready to perform troubleshooting steps before calling.



KNOWLEDGE IS POWER

Enhance your installation and fabrication skills by enrolling in the most recognized and respected mobile electronics school in our industry. Log onto www.installerinstitute.com or call 800-354-6782 for more information and take steps toward a better tomorrow.



Metra recommends MECP certified technicians