



Kia Soul (without NAV, with Display radio) 2017-2019

Visit MetraOnline.com for more detailed information about the product and up-to-date vehicle specific applications

† Display radio is an Android Auto / Apple CarPlay radio

KIT FEATURES

- ISO DIN radio provision with pocket
- ISO DDIN radio provision
- Includes climate display for fan speed, mode, and temp, which was displayed on the factory radio
- Includes an ASWC-1, AX-CAM6V, antenna adapter, and wiring harness for a complete installation
- Painted high gloss black

KIT COMPONENTS

- A) Radio/climate trim panel with climate display
- B) Radio brackets
- C) Pocket
- D) Heated seat blank plugs
- E) (4) #8 x 3/8" Phillips screws
- F) (6) Panel clips
- G) Wiring harness (not shown)

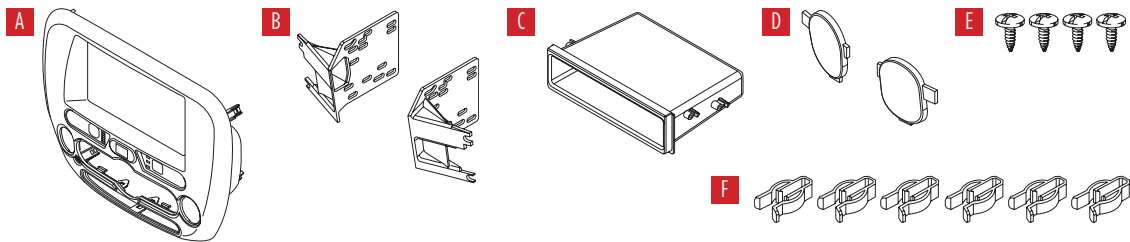

TABLE OF CONTENTS

Dash Disassembly.....	2
Kit Preparation.....	2
Kit Assembly	
–ISO DIN radio provision with pocket.....	3
–ISO DDIN radio provision.....	3
Wiring Instructions.....	4-11

WIRING & ANTENNA CONNECTIONS (sold separately)

Wiring harness: Included with kit

Antenna adapter: Included with kit

Steering wheel control interface: ASWC-1 included with kit

12v to 6v camera step-down: AX-CAM6V Included with kit

TOOLS REQUIRED

- Panel removal tool
- Phillips screwdriver

Attention! Let the vehicle sit with the key out of the ignition for a few minutes before removing the factory radio. When testing the aftermarket equipment, ensure that all factory equipment is connected before cycling the key to ignition.

DASH DISASSEMBLY

1. Unclip the climate panel surrounding the radio and set to the side. (Figure A)
2. Remove (4) Phillips screws securing the radio. Slide the radio out, then unplug and remove the radio. (Figure B)

Continue to Kit Preparation

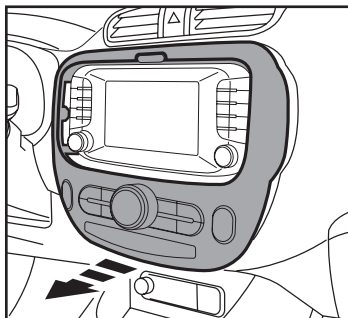

(Figure A)

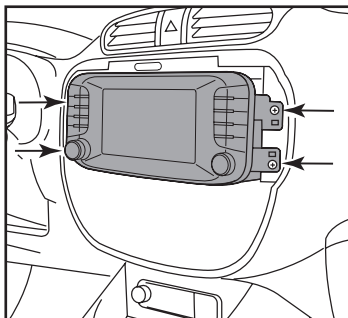

(Figure B)

KIT PREPARATION

From the factory climate panel:

1. Remove (4) Phillips screws securing the climate controls and passenger airbag switch panel, then remove the components. (Figure A)

To the 99-7387HG radio/climate trim panel with climate display:

2. If the vehicle is not equipped with heated seats, snap in the heated seat blank plugs. (Figure B)
3. Secure the climate controls and passenger airbag switch panel using the factory screws. (Figure C)

Continue to Kit Assembly

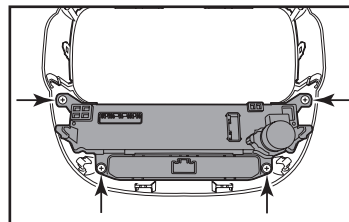

(Figure A)

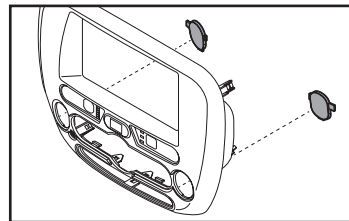

(Figure B)

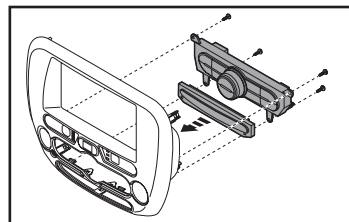

(Figure C)

KIT ASSEMBLY

ISO DIN radio provision with pocket

1. Secure the *radio brackets* to the *pocket* using the (4) #8 x 3/8" Phillips screws provided. (Figure A)
2. Remove the metal DIN sleeve and trim ring from the aftermarket radio.
3. Slide the radio into the bracket/pocket assembly, then secure it to the assembly using the screws supplied with the radio. (Figure B)

Continue to Wiring Instructions

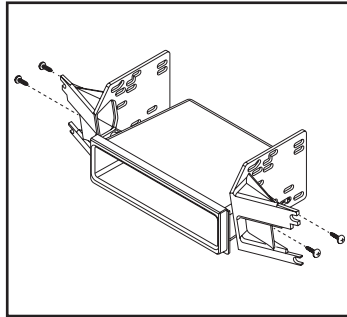

(Figure A)

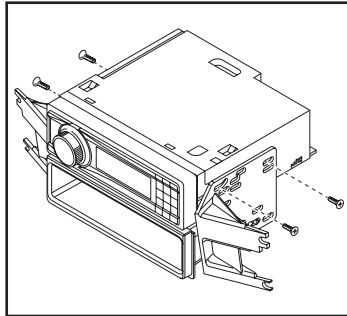

(Figure B)

ISO DDIN radio provision

1. Secure the *radio brackets* to the radio using the screws supplied with the radio. (Figure A)

Continue to Wiring Instructions

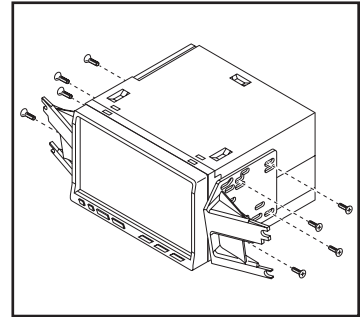

(Figure A)

WIRING INSTRUCTIONS

FEATURES

- Retains audio controls on the steering wheel via an ASWC-1
- Provides NAV outputs (speed sense)
- Retains the factory backup camera
- Includes an AX-CAM6V 12-to-6V step-down for the factory camera

COMPONENTS

- ASWC-1
- AX-CAM6V
- 7387 wiring harness

TABLE OF CONTENTS

Connections.....	5-6
Installation	6
Programming the ASWC-1 and climate display	7
Final assembly.....	7
(ASWC-1) Steering wheel control settings	8-11
- L.E.D. feedback	
- Changing radio type	
- Remapping the steering wheel control buttons	
- Dual assignment instructions (long button press)	

TOOLS REQUIRED

- Crimping tool and connectors, or solder gun, solder, and heat shrink
- Tape • Wire cutter • Zip ties

CONNECTIONS

From the wiring harness included with the kit to the aftermarket radio:

- Connect the (2) **Black** wires, and also the **Black** wire labeled “CAMERA GROUND”, to the ground wire, and also to the **Black** wire from the AX-CAM6V.
- Connect the **Yellow** wire to the battery wire.
- Connect the **Red** wire to the accessory wire.
- Connect the **Red** wire labeled “6-volt camera power” to the **Blue/Red** wire from the AX-CAM6V.
- Connect the **Blue/White** wire from the AX-CAM6V to reverse power. This wire will have to be sourced in the vehicle.
- Connect the **Blue** wire to the power antenna wire.
- If the aftermarket radio has an illumination wire, connect the **Orange** wire to it.
- Connect the **Gray** wire to the right front positive speaker output.
- Connect the **Gray/Black** wire to the right front negative speaker output.
- Connect the **White** wire to the left front positive speaker output.
- Connect the **White/Black** wire to the left front negative speaker output.
- Connect the **Green** wire to the left rear positive speaker output.
- Connect the **Green/Black** wire to the left rear negative speaker output.
- Connect the **Purple** wire to the right rear positive speaker output.
- Connect the **Purple/Black** wire to the right rear negative output.

The following (1) wire is only for a multimedia/navigation radio that requires this wire.

- Connect the **Blue/Pink** wire to the VSS/speed sense wire.
- If retaining the factory AUX-IN jack, connect the **Red** and **White** RCA jacks to the audio AUX-IN jacks.
- Connect the **Yellow** RCA jack to the backup camera input.

Continued on the next page

3.5mm jack steering wheel control retention:

The 3.5mm jack is to be used to retain audio controls on the steering wheel.

- **For the radios listed below:** Connect the *female 3.5mm connector with stripped leads* included with the ASWC-1, to the male 3.5mm SWC jack from the wiring harness included with the kit. Any remaining wires tape off and disregard:
 - **Eclipse:** Connect the steering wheel control wire, normally **Brown**, to the **Brown/White** wire from the connector. Then connect the remaining steering wheel control wire, normally **Brown/White**, to the **Brown** wire from the connector.
 - **Metra OE:** Connect the steering wheel control Key 1 wire (**Gray**) to the **Brown** wire.
 - **Kenwood or select JVC with a steering wheel control wire:** Connect the **Blue/Yellow** wire to the **Brown** wire.
Note: If the **Kenwood** radio auto detects as a **JVC**, manually set the radio type to **Kenwood**. See the instructions under **Changing Radio Type**.
 - **XITE:** Connect the steering wheel control SWC-2 wire from the radio to the **Brown** wire.
 - **Parrot Asteroid Smart or Tablet:** Connect the 3.5mm jack into the AX-SWC-PARROT (sold separately), and then connect the 4-pin connector from the AX-SWC-PARROT into the radio.
Note: The radio must have rev. 2.1.4 or higher software.
 - **Universal “2 or 3 wire” radio:** Connect the steering wheel control wire, referred to as Key-A or SWC-1, to the **Brown** wire from the connector. Then connect the remaining steering wheel control wire, referred to as Key-B or SWC-2, to the **Brown/White** wire from the connector. If the radio comes with a third wire for ground, disregard this wire. **Note:** After the interface has been programmed to the vehicle, refer to the manual provided with the radio for assigning the SWC buttons. Contact the radio manufacturer for more information.
- **For all other radios:** Connect the 3.5mm jack from the 7387 harness into the jack from the aftermarket radio designated for an external steering wheel control interface. Please refer to the aftermarket radios manual if in doubt as to where the 3.5mm jack should connect to.

With the key in the off position:

1. Connect the wiring harness included with the kit to the *climate display*, and then to the wiring harness in the vehicle.
2. Locate the factory antenna connector in the dash and complete all necessary connections to the radio. Use the antenna adapter provided to adapt the factory antenna connector to the aftermarket radio.
3. Connect the wiring harness included with the kit to the ASWC-1.

Attention! If retaining steering wheel controls, ensure that the SWC jack/wire is connected to the radio before proceeding. If this step is skipped, the ASWC-1 will need to be reset for the steering wheel controls to function.

PROGRAMMING THE ASWC-1 AND CLIMATE DISPLAY

Programming the ASWC-1:

1. Press and hold the **Volume Up** button on the steering wheel, then turn the ignition on. The L.E.D. will start flashing rapidly, which means the ASWC-1 is looking for the vehicle and the radio.
Note: If the L.E.D. did not start flashing rapidly, press the reset button for 3 seconds.
2. After a few seconds the L.E.D. should stop flashing rapidly, and then go out for approximately 2 seconds.
3. After approximately 2 seconds there will be a series of 7 **Green** flashes, some short, and some long. The long flashes represent the wires that are connected to the ASWC-1.
Tip: Knowing this will help to troubleshoot, if need be.
4. The L.E.D. will pause for another 2 seconds, and then flash **Red** up to 18 times depending on which radio is connected to the ASWC-1. Refer to the **L.E.D. Feedback** section for information.
5. This is the end of the auto detection stage. If the ASWC-1 detected the vehicle and the radio successfully, the L.E.D. will light up solid. Release from holding the **Volume Up** button.

Programming the climate display:

7. Turn the parking lights on.
8. Turn the vehicles light dimmer all the way down, then all the way up.
9. Turn the lights off.
10. Test all functions of the installation for proper operation, before reassembling the dash. Refer to the **ASWC-1 Steering wheel control settings** for customizing the buttons, if so desired.

FINAL ASSEMBLY

1. Secure the radio assembly to the dash using the factory screws.
2. Reassemble the dash in reverse order of disassembly to complete the installation.

(ASWC-1) STEERING WHEEL CONTROL SETTINGS

L.E.D. feedback

The (18) **Red** L.E.D. flashes represent what brand radio the ASWC-1 believes it is connected to. Each flash represents a different radio Manufacturer. For example, if you are installing a JVC radio, the ASWC-1 will flash **Red** (5) times, and then stop. Following is a legend that dictates which radio Manufacturer corresponds to which flash.

L.E.D. feedback legend

1 flash - Eclipse (Type 1) †	7 flashes - Alpine *	13 flashes - LG
2 flashes - Kenwood ‡	8 flashes - Visteon	14 flashes - Parrot **
3 flashes - Clarion (Type 1) †	9 flashes - Valor	15 flashes - XITE
4 flashes - Sony/Dual	10 flashes - Clarion (Type 2) †	16 flashes - Philips
5 flashes - JVC	11 flashes - Metra OE	17 flashes - TBA
6 flashes - Pioneer/Jensen	12 flashes - Eclipse (Type 2) †	18 flashes - JBL

*** Note:** If the ASWC-1 flashes **Red** (7) times, and you do not have an Alpine radio connected to it, that means the ASWC-1 does not detect a radio connected to it. Verify that the 3.5mm jack is connected to the correct steering wheel jack/wire in the radio.

**** Note:** The AX-SWC-PARROT is required (sold separately). Also, the Parrot radio must have rev. 2.1.4 or higher software.

† Note: If you have a Clarion radio and the steering wheel controls do not work, change the radio type to the other Clarion radio type; same for Eclipse. The following section explains how to do this.

‡ Note: If you have a Kenwood radio and the L.E.D. feedback comes back showing as a JVC radio, change the radio type to Kenwood. The following section explains how to do this.

Attention: The Axxess Updater App can also be used to program the following (3) sub-sections as well, pending that the ASWC-1 has been programmed.

Continued on the next page

(ASWC-1) STEERING WHEEL CONTROL SETTINGS (CONT.)

Changing radio type

If the L.E.D. flashes do not match the radio you have connected, you must manually program the ASWC-1 to tell it what radio it is connected to.

1. After (3) seconds of turning the key on, press and hold the **Volume Down** button on the steering wheel until the L.E.D. in the ASWC-1 goes solid.
2. Release the **Volume Down** button; the L.E.D. will go out indicating the ASWC-1 is in **Changing Radio Type** mode.
3. Refer to the **Radio Legend** to know which radio number you would like to have programmed.
4. Press and hold the **Volume Up** button until the L.E.D. goes solid, and then release. Repeat this step for the desired radio number you have selected.
5. Once the desired radio number has been selected, press and hold the **Volume Down** button on the steering wheel until the L.E.D. goes solid. The L.E.D. will remain on for about (3) seconds while it stores the new radio information.
6. Once the L.E.D. goes out, the **Changing Radio Type** mode will then end. You can now test the steering control wheel controls.

Note: If at any time the user fails to press any button for a period longer than (10) seconds, this process will abort.

Radio legend

1 flash - Eclipse (Type 1) †	7 flashes - Alpine *	13 flashes - LG
2 flashes - Kenwood ‡	8 flashes - Visteon	14 flashes - Parrot **
3 flashes - Clarion (Type 1) †	9 flashes - Valor	15 flashes - XITE
4 flashes - Sony/Dual	10 flashes - Clarion (Type 2) †	16 flashes - Philips
5 flashes - JVC	11 flashes - Metra OE	17 flashes - TBA
6 flashes - Pioneer/Jensen	12 flashes - Eclipse (Type 2) †	18 flashes - JBL

Continued on the next page

(ASWC-1) STEERING WHEEL CONTROL SETTINGS (CONT.)

Remapping the steering wheel control buttons

Once the ASWC-1 has been programmed, the button assignment for the steering wheel controls may be reassigned if so desired. For example, if the **Seek Up** button is preferred to be the **Mute** button instead. Follow the steps below to remap the steering wheel control buttons.

1. Ensure the ASWC-1 is visible so you can see the L.E.D. flashes to confirm button recognition.

Tip: Turning the radio off is recommended.

2. Within the first twenty seconds of turning the ignition on, press and hold the **Volume Up** button on the steering wheel until the L.E.D. goes solid.
3. Release the **Volume Up** button, the L.E.D. will then go out; The **Volume Up** button has now been programmed.
4. Follow the list in the **Button Function Legend** to reference the order in which the steering wheel control buttons need to be programmed.

Note: If the next function on the list is not on the steering wheel, press the **Volume Up** button for (1) second until the L.E.D. comes on to skip that function, and then release the **Volume Up** button. This will tell the ASWC-1 that this function is not available, and it will move on to the next function.

5. To complete the remapping process, press and hold the **Volume Up** button until the L.E.D. in the ASWC-1 goes out.

Button Function Legend

1. Volume-Up	7. Preset-Up	13. On-Hook
2. Volume-Down	8. Preset-Down	14. Off-Hook
3. Seek-Up/Next	9. Power	15. Fan-Up *
4. Seek-Down/Prev	10. Band	16. Fan-Down *
5. Source/Mode	11. Play/Enter	17. Temp-Up *
6. Mute	12. PTT (Push to Talk)	18. Temp-Down *

* Not applicable in this application

Note: Some radios may not have these commands. Please refer to the manual provided with the radio, or contact the radio manufacturer for specific commands recognized by that particular radio.

Continued on the next page

(ASWC-1) STEERING WHEEL CONTROL SETTINGS (CONT.)

Dual assignment instructions (long button press)

The ASWC-1 has the capability to assign (2) functions to a single button, except **Volume Up** and **Volume Down**. Follow the steps below to program the button(s) to the desired setting.

Note: **Seek Up** and **Seek Down** come pre-programmed as **Preset Up** and **Preset Down** for a long button press.

1. Turn the key to ignition but do not start the vehicle.
2. Press and hold the desired steering wheel control button for (10) seconds, or until the L.E.D. flashes rapidly. At this point release the button; the L.E.D. will then go solid.
3. Press and release the **Volume Up** button the number of times corresponding to the new button number selected. Refer to the **Dual Assignment Legend**. The L.E.D. will flash rapidly while the **Volume Up** button is being pressed, and then go back to a solid L.E.D. once released. Proceed to the next step once the **Volume Up** button has been pressed the desired number of times.

Caution: If more than (10) seconds elapses between pressing the **Volume Up** button, this procedure will abort, and the L.E.D. will go out.

4. Press the desired button to store it to memory. The L.E.D. will now go out indicating the new information has been stored to memory.

Note: These steps must be repeated for each button desired to assign a dual assignment feature to. To reset a button back to its default state, repeat Step 1, then press the **Volume Down** button. The L.E.D. will go out, and the dual assignment feature for that button will be erased.

Dual Assignment legend

- | | | |
|-------------------|------------------------|-----------------|
| 1. Not allowed | 7. Preset-Up | 13. On-Hook |
| 2. Not allowed | 8. Preset-Down | 14. Off-Hook |
| 3. Seek-Up/Next | 9. Power | 15. Fan-Up * |
| 4. Seek-Down/Prev | 10. Band | 16. Fan-Down * |
| 5. Mode/Source | 11. Play/Enter | 17. Temp-Up * |
| 6. ATT/Mute | 12. PTT (Push to Talk) | 18. Temp-Down * |

* Not applicable in this application



99-7387HG
INSTALLATION INSTRUCTIONS



If you are having difficulties with the installation of this product, contact our Tech Support line either by phone at **1-800-253-TECH**, or email at **techsupport@metra-autosound.com**. Before doing so, look over the instruction booklet a second time and ensure that the installation was performed exactly as the instruction booklet is stated. Have the vehicle apart and ready to perform troubleshooting steps before contacting Metra/Axxess Tech Support.



KNOWLEDGE IS POWER

Enhance your installation and fabrication skills by enrolling in the most recognized and respected mobile electronics school in our industry. Log onto www.installerinstitute.com or call 800-354-6782 for more information and take steps toward a better tomorrow.



Metra recommends MECP certified technicians